

TECHNICAL SPECIFICATION

**Recommendations for renewable energy and hybrid systems for rural
electrification –
Part 7: Generators**





THIS PUBLICATION IS COPYRIGHT PROTECTED
Copyright © 2017 IEC, Geneva, Switzerland

All rights reserved. Unless otherwise specified, no part of this publication may be reproduced or utilized in any form or by any means, electronic or mechanical, including photocopying and microfilm, without permission in writing from either IEC or IEC's member National Committee in the country of the requester. If you have any questions about IEC copyright or have an enquiry about obtaining additional rights to this publication, please contact the address below or your local IEC member National Committee for further information.

IEC Central Office
3, rue de Varembe
CH-1211 Geneva 20
Switzerland

Tel.: +41 22 919 02 11
Fax: +41 22 919 03 00
info@iec.ch
www.iec.ch

About the IEC

The International Electrotechnical Commission (IEC) is the leading global organization that prepares and publishes International Standards for all electrical, electronic and related technologies.

About IEC publications

The technical content of IEC publications is kept under constant review by the IEC. Please make sure that you have the latest edition, a corrigenda or an amendment might have been published.

IEC Catalogue - webstore.iec.ch/catalogue

The stand-alone application for consulting the entire bibliographical information on IEC International Standards, Technical Specifications, Technical Reports and other documents. Available for PC, Mac OS, Android Tablets and iPad.

IEC publications search - www.iec.ch/searchpub

The advanced search enables to find IEC publications by a variety of criteria (reference number, text, technical committee,...). It also gives information on projects, replaced and withdrawn publications.

IEC Just Published - webstore.iec.ch/justpublished

Stay up to date on all new IEC publications. Just Published details all new publications released. Available online and also once a month by email.

Electropedia - www.electropedia.org

The world's leading online dictionary of electronic and electrical terms containing 20 000 terms and definitions in English and French, with equivalent terms in 16 additional languages. Also known as the International Electrotechnical Vocabulary (IEV) online.

IEC Glossary - std.iec.ch/glossary

65 000 electrotechnical terminology entries in English and French extracted from the Terms and Definitions clause of IEC publications issued since 2002. Some entries have been collected from earlier publications of IEC TC 37, 77, 86 and CISPR.

IEC Customer Service Centre - webstore.iec.ch/csc

If you wish to give us your feedback on this publication or need further assistance, please contact the Customer Service Centre: csc@iec.ch.



TECHNICAL SPECIFICATION

**Recommendations for renewable energy and hybrid systems for rural
electrification –
Part 7: Generators**

INTERNATIONAL
ELECTROTECHNICAL
COMMISSION

ICS 27.160

ISBN 978-2-8322-4844-7

Warning! Make sure that you obtained this publication from an authorized distributor.

CONTENTS

FOREWORD.....	3
INTRODUCTION.....	5
1 Scope.....	6
2 Normative references	6
3 Terms and definitions	6
4 General	8
5 Generator boundaries.....	8
6 Generators requirements.....	9
6.1 General requirements	9
6.2 Specific requirements for the different technologies	9
6.2.1 Input requirements.....	9
6.2.2 Output requirements	11
6.2.3 Specific requirements for different generator technologies.....	11
7 Generator design and sizing	12
8 Hybrid generation	12
Bibliography.....	13
Figure 1 – General electrical configuration of a collective electrification system.....	8
Table 1 – General inputs and outputs to be considered for generator specification	9
Table 2 – Input requirements relative to the generator technology	10
Table 3 – Output requirements relative to the generator technology.....	11
Table 4 – Specific generators requirements considered in the IEC 62257 series	12

INTERNATIONAL ELECTROTECHNICAL COMMISSION

**RECOMMENDATIONS FOR RENEWABLE ENERGY
AND HYBRID SYSTEMS FOR RURAL ELECTRIFICATION –****Part 7: Generators**

FOREWORD

- 1) The International Electrotechnical Commission (IEC) is a worldwide organization for standardization comprising all national electrotechnical committees (IEC National Committees). The object of IEC is to promote international co-operation on all questions concerning standardization in the electrical and electronic fields. To this end and in addition to other activities, IEC publishes International Standards, Technical Specifications, Technical Reports, Publicly Available Specifications (PAS) and Guides (hereafter referred to as “IEC Publication(s)”). Their preparation is entrusted to technical committees; any IEC National Committee interested in the subject dealt with may participate in this preparatory work. International, governmental and non-governmental organizations liaising with the IEC also participate in this preparation. IEC collaborates closely with the International Organization for Standardization (ISO) in accordance with conditions determined by agreement between the two organizations.
- 2) The formal decisions or agreements of IEC on technical matters express, as nearly as possible, an international consensus of opinion on the relevant subjects since each technical committee has representation from all interested IEC National Committees.
- 3) IEC Publications have the form of recommendations for international use and are accepted by IEC National Committees in that sense. While all reasonable efforts are made to ensure that the technical content of IEC Publications is accurate, IEC cannot be held responsible for the way in which they are used or for any misinterpretation by any end user.
- 4) In order to promote international uniformity, IEC National Committees undertake to apply IEC Publications transparently to the maximum extent possible in their national and regional publications. Any divergence between any IEC Publication and the corresponding national or regional publication shall be clearly indicated in the latter.
- 5) IEC itself does not provide any attestation of conformity. Independent certification bodies provide conformity assessment services and, in some areas, access to IEC marks of conformity. IEC is not responsible for any services carried out by independent certification bodies.
- 6) All users should ensure that they have the latest edition of this publication.
- 7) No liability shall attach to IEC or its directors, employees, servants or agents including individual experts and members of its technical committees and IEC National Committees for any personal injury, property damage or other damage of any nature whatsoever, whether direct or indirect, or for costs (including legal fees) and expenses arising out of the publication, use of, or reliance upon, this IEC Publication or any other IEC Publications.
- 8) Attention is drawn to the Normative references cited in this publication. Use of the referenced publications is indispensable for the correct application of this publication.
- 9) Attention is drawn to the possibility that some of the elements of this IEC Publication may be the subject of patent rights. IEC shall not be held responsible for identifying any or all such patent rights.

The main task of IEC technical committees is to prepare International Standards. In exceptional circumstances, a technical committee may propose the publication of a technical specification when

- the required support cannot be obtained for the publication of an International Standard, despite repeated efforts, or
- the subject is still under technical development or where, for any other reason, there is the future but no immediate possibility of an agreement on an International Standard.

Technical specifications are subject to review within three years of publication to decide whether they can be transformed into International Standards.

IEC 62257-7, which is a technical specification, has been prepared by IEC technical committee 82: Solar photovoltaic energy systems.

This second edition cancels and replaces the first edition published in 2008. This edition constitutes a technical revision.

This edition includes the following significant technical changes with respect to the previous edition:

- a) Removed the word "small" from the description of the PV systems, and removed the power limit (100 kVA).
- b) Increased the relevant voltage levels to 1 000 V (AC) and 1 500 V (DC).

This technical specification is to be used in conjunction with other parts of this series.

The text of this technical specification is based on the following documents:

Enquiry draft	Report on voting
82/1201/DTS	82/1258/RVDTS

Full information on the voting for the approval of this technical specification can be found in the report on voting indicated in the above table.

This document has been drafted in accordance with the ISO/IEC Directives, Part 2.

A list of all parts of IEC 62257 series, under the general title: *Recommendations for renewable energy and hybrid systems for rural electrification*, can be found on the IEC website.

The committee has decided that the contents of this publication will remain unchanged until the stability date indicated on the IEC website under "<http://webstore.iec.ch>" in the data related to the specific publication. At this date, the publication will be

- transformed into an International standard,
- reconfirmed,
- withdrawn,
- replaced by a revised edition, or
- amended.

A bilingual version of this publication may be issued at a later date.

INTRODUCTION

The IEC 62257 series of documents intends to provide to different players involved in rural electrification projects (such as project implementers, project contractors, project supervisors, installers, etc.) documents for the setting-up of renewable energy and hybrid systems with AC voltage below 1 000 V and DC voltage below 1 500 V.

These documents are recommendations:

- to choose the right system for the right place;
- to design the system;
- to operate and maintain the system.

These documents are focused only on rural electrification, concentrating on but not specific to, developing countries. They must not be considered as all-inclusive to rural electrification. The documents try to promote the use of renewable energies in rural electrification; they do not deal with clean development mechanisms at this time (CO₂ emission, carbon credit, etc.). Further developments in this field could be introduced in future steps.

This consistent set of documents is best considered as a whole with different parts corresponding to items for safety, sustainability of systems and at the lowest life-cycle cost as possible. One of the main objectives is to provide the minimum sufficient requirements, relevant to the field of application, that is, renewable energy and hybrid off-grid systems.

The purpose of this part of IEC 62257 is to provide project implementers with general information about generators and to highlight the main characteristics relative to the different technologies that can be used.

RECOMMENDATIONS FOR RENEWABLE ENERGY AND HYBRID SYSTEMS FOR RURAL ELECTRIFICATION –

Part 7: Generators

1 Scope

This part of IEC 62257 specifies the general requirements for the generators in decentralized rural electrification systems.

This document is a general introduction followed by more specific documents dedicated to the generation technologies which are the most currently used in rural electrification projects.

2 Normative references

The following documents are referred to in the text in such a way that some or all of their content constitutes requirements of this document. For dated references, only the edition cited applies. For undated references, the latest edition of the referenced document (including any amendments) applies.

IEC TS 62257-2:2015, *Recommendations for renewable energy and hybrid systems for rural electrification – Part 2: From requirements to a range of electrification systems*

IEC TS 62257-4, *Recommendations for renewable energy and hybrid systems for rural electrification – Part 4: System selection and design*

IEC TS 62257-5, *Recommendations for renewable energy and hybrid systems for rural electrification – Part 5: Protection against electrical hazards*

IEC TS 62257-7-1, *Recommendations for renewable energy and hybrid systems for rural electrification – Part 7-1: Generators – Photovoltaic generators¹*

IEC TS 62257-7-3, *Recommendations for renewable energy and hybrid systems for rural electrification – Part 7-3: Generator set – Selection of generator sets for rural electrification systems¹*

IEC TS 62257-9-1, *Recommendations for renewable energy and hybrid systems for rural electrification – Part 9-1: Integrated systems – Micropower systems*

3 Terms and definitions

For the purposes of this document, the following terms and definitions apply.

ISO and IEC maintain terminological databases for use in standardization at the following addresses:

- IEC Electropedia: available at <http://www.electropedia.org/>
- ISO Online browsing platform: available at <http://www.iso.org/obp>

¹ Third edition to be published. A second edition (dated 2010) already exists.

3.1**generator**

apparatus that converts one form of energy into electricity

[SOURCE: IEC TS 61836:2016, 3.3.27, modified: "non-electric energy" changed to "one form of energy"]

3.2**dispatchable power system**

power system where delivered electricity is available as scheduled

(ex: a fossil-fuelled engine-powered generator is dispatchable. A renewable energy generator is usually a non-dispatchable power system)

[SOURCE: IEC TS 61836:2016, 3.3.67.1, modified to describe "dispatchable"]

3.3**non-dispatchable power system**

non-dispatchable system is resource dependent; power might not be available at a specified time

3.4**collective electrification system**

small electric generating system and minigrid that supplies electricity to multiple consumption points from a single or multiple energy sources

[SOURCE: IEC TS 61836:2016, 3.3.12]

3.5**individual electrification system**

small electric generating system that supplies electricity to one consumption point, such as a household, usually from a single energy source

[SOURCE: IEC TS 61836:2016, 3.3.34]

3.6**interface**

boundary between two systems or the equipment facilitating the interconnection of two systems

3.7**genset**

colloquial term meaning "engine-generator set" consisting of a fossil-fuelled engine coupled to an electric generator

[SOURCE: IEC TS 61836:2016, 3.3.28]

3.8**microgrid**

grid that operates at less than 100 kVA of capacity and is electrified by a micropower system

3.9**micropower system**

generating system that produces less than 100 kVA through the use of a single source or a multi-source system

3.10 user installation

electrical installation located in the user’s house, powering the user’s appliances and connected to the interface with the microgrid

4 General

In an electrification system, a generator is a part of the energy production subsystem. Different architectures of energy production subsystems are provided in IEC TS 62257-2 along with some recommendations for selecting the relevant energy production subsystems matching both sources and demand requirements. (IEC TS 62257-2:2015, Annex D).

An energy production subsystem may include one or several generators of the same technology or of different technologies (hybrid production). Recommendations to configure hybrid power systems are provided in IEC TS 62257-9-1. According to the availability of the primary resource, the generators can be classified as dispatchable or non-dispatchable.

5 Generator boundaries

Figure 1 illustrates the position of the generator in an electrification system.

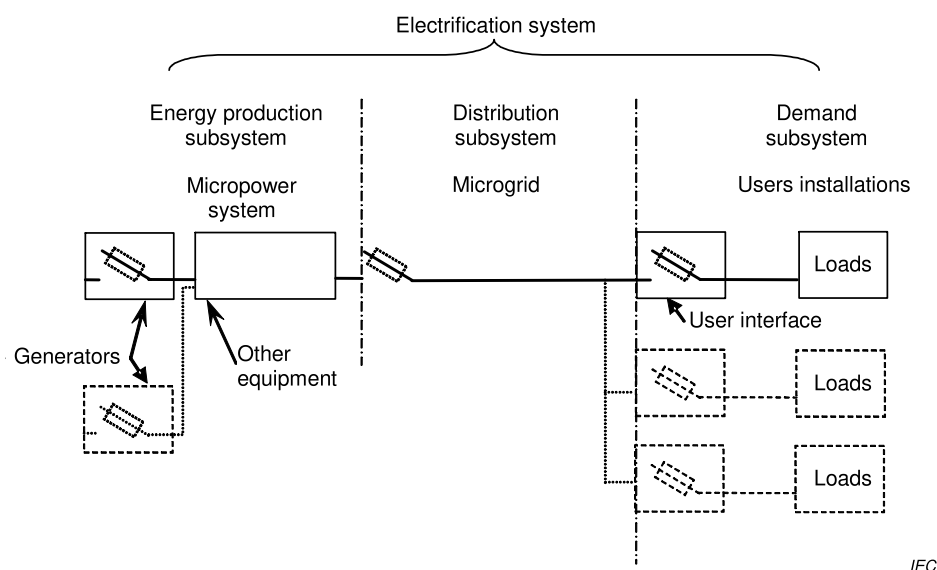

Figure 1 – General electrical configuration of a collective electrification system

NOTE 1 As explained in IEC TS 62257-4, a collective electrification systems is composed of 3 parts as shown in Figure 1; an individual electrification system does not include a distribution subsystem, but could be powered by a micropower system.

NOTE 2 Micropower systems are addressed in IEC TS 62257-9-1.

The generator embodies everything needed to produce electric power corresponding to the necessary characteristics of voltage, frequency, harmonics, power and consumption of the customers, according to the needed quality of service.

In the IEC 62257-7 series, “generator” means “installed generator”. Are included in a generator:

- The generator itself, able to produce electricity from a primary source of energy (sun, wind, fuel, water).

- The associated internal control devices.
- The associated protective devices.
- The associated connecting devices with other equipment of the micro power system (busbars, etc.).
- The necessary infrastructure and civil engineering.

6 Generators requirements

6.1 General requirements

When defining the generator characteristics, the following “inputs” and “outputs” shall be taken into consideration, as indicated in Table 1.

Table 1 – General inputs and outputs to be considered for generator specification

Input requirements (constraints)	Generator characteristics	Output requirements (results)
Primary energy resources (sun, wind, water flow/head, fuel) Environmental conditions (air pressure/humidity/ temperature) Signals (start/stop, synchronization) Regulations / Standards Assessment of energy demand Assessment of energy quality requirements	Technology Size Weight Volume Protection Housing Civil engineering Maintenance requirements Internal control	Electrical performances (voltage, current, power, frequency) Safety (people, equipment) Environmental impacts (exhaust, heat, noise)

6.2 Specific requirements for the different technologies

6.2.1 Input requirements

Table 2 gives examples of issues that have to be addressed concerning the site characteristics in order to assess whether the generator is relevant to the requirements of the general specification.

Table 2 – Input requirements relative to the generator technology

Input requirements (constraints)	Issues to be addressed			
	PV array	Wind turbine	Genset	Micro hydro turbine
Resource availability	Only during daylight and variable according to the season	High short-term variability; seasonality and extreme conditions (storm)	Linked to site accessibility and local storage capabilities	Day and night availability; seasonality and extreme conditions (overflow)
Resource assessment	Possibility of extrapolation of existing data concerning a neighbouring area	Extrapolation of existing data requires the use of dedicated software and a thorough assessment of the site configuration	Easy evaluation of sourcing and of possibility of transportation and recycling drums	In most cases, no existing data available; on site measurement of flow and observation of seasonal variations
Resource level	Production of a given array could vary by a factor of 4 depending on site solar irradiation and temperature characteristics	A minimum wind speed is required to start production Production is strongly dependant on wind speed, theoretically on a cubic law	Specific consumption (l/kWh) varies with load factor and altitude	A minimum water flow or head is required
Possibility to install the generator as close as possible to the energy utilisation	Yes, if (mostly unshaded) area is available	Not always practical The wind resource is dependant on the location In a few cases small wind turbines can be installed directly on roofs Consider also noise problems	Yes; but see environmental impact Consider also noise and vibration problems	Not always practical The location is dependant on the water resource
Space availability for installing the generator	The ratio surface / power installed is high for PV arrays compared to other generator Small PV array can be installed directly on roofs	Space for setting up include the stays installation and possibility to lay down the turbine for maintenance	The ratio surface / power is the smallest Additional space for fuel storage is needed	The infrastructure is very dependant of the technology and of the necessary head
Site characteristics to be considered	Shadowing	Roughness, obstacles, etc.	Accessibility for fuel transportation	Accessibility to the water resource
Civil engineering constraint level	Low to medium, depending on the configuration of the ground, the consistency of the soil, the quality of the roofs	Medium to high depending on the configuration of the ground, the consistency of the soil or the quality of the roof Depends on the size and technology of the wind turbine	Low	Could be high depending on the slope and width of the river
Needed operation skill	Low	Low, but high for maintenance operation	Low, but high for heavy maintenance operation	Low, but medium for maintenance operation
Operation constraints	Batteries storage or hybridation needed to adapt the production to the demand	Batteries storage or hybridation needed to adapt the production to the demand	To operate between 50 % and 80 % of the rated power to ensure the nominal lifetime of the engine Fuel storage needed	To adjust the settings of the turbine in relation to the available flow and the electricity demand

NOTE Different levels of accuracy to collect resources and demand data are given in IEC TS 62257-4.

6.2.2 Output requirements

Table 3 highlights the issues that have to be solved for each type of generator regarding the different output requirements listed in the general specification (GS).

Table 3 – Output requirements relative to the generator technology

Output requirements (results)	Issues to be solved			
	PV array	Wind turbine	Genset	Micro hydro turbine
Electrical performances (loads and quality of service)	Voltage forming needed (battery, hybridation) Storage to adapt production to demand Energy conversion needed if a.c. demand	Voltage and frequency regulation by an external mean Storage needed to adapt production to demand Energy conversion needed when using wind turbines for battery charging	Internal voltage and frequency regulation	Voltage and frequency regulation by flow or demand regulation Storage needed in some cases Energy conversion needed when using battery charging
Safety issues	Electrical Mechanical (wind effect on PV array)	Electrical Moving parts Mechanical (erection / laying down the machine)	Electrical Moving parts Heat Fire hazard	Electrical Moving parts Water pressure
Environmental impact	Visual Ground occupation Battery recycling (if battery storage)	Visual Noise and vibration Battery recycling (if battery storage)	Noise Soil pollution due to oil and fuel Air pollution due to exhaust Heat	Visual (especially due to the weir and the penstock, if any) Fauna and flora impact

Electrical performances shall be defined in order to supply the quality level as required in the GS of the project. Supply quality indicators are given in IEC TS 62257-2:2015, Annex C, Table C.1.

Safety recommendations include general electrical safety requirements from IEC TS 62257-5 (common to all generators) but attention shall be paid to the specific aspects related to each technology (mechanical hazards, moving parts, fire hazards, high temperature, etc.).

The design of the generator shall take into account the characteristics of the appliances to be supplied (e.g. a poor power factor implies the oversizing of the generator).

6.2.3 Specific requirements for different generator technologies

Specific requirements for different technologies are addressed in the following technical specifications as indicated in Table 4.

**Table 4 – Specific generators requirements considered
in the IEC 62257 series**

Designation	IEC 62257 reference
PV array	IEC TS 62257-7-1
Wind turbine	
Generating set	
Micro-hydro turbine	
	IEC TS 62257-7-3

7 Generator design and sizing

Power and energy can be supplied by one or several combined generators.

The generator or a hybrid micropower system including several generators shall be sized and designed to provide the peak power and the energy required by the GS.

The main architectures of micropower systems are provided in IEC TS 62257-2.

Several strategies may be developed to ensure both the satisfaction of customers and profitability of the project. The oversizing of the generator may increase the satisfaction of customers, but can also endanger the profitability of the project. Attention shall be paid to the fact that for generating sets oversizing can also be a technical risk (refer to IEC TS 62257-7-3).

In order to help optimizing the techno-economic calculations of systems, refer to IEC TS 62257-4.

The GS requires a specified level of quality of supply for voltage and current supplied to the customer. Therefore, generators shall be selected, designed and sized in order to be able to provide the required level of quality. For that purpose, important parameters shall be taken into account, such as the appliances to be powered, the length of the microgrid, the architecture of the micropower system (one or several generators, mix of technologies, storage, etc.).

8 Hybrid generation

Specific requirements for the combination of different generators in a micropower system are addressed in IEC TS 62257-9-1.

Bibliography

IEC TS 61836:2016, *Solar photovoltaic energy systems – Terms, definitions and symbols*

IEC TS 62257-1, *Recommendations for renewable energy and hybrid systems for rural electrification - Part 1: General introduction to IEC 62257 series and rural electrification*

INTERNATIONAL
ELECTROTECHNICAL
COMMISSION

3, rue de Varembé
PO Box 131
CH-1211 Geneva 20
Switzerland

Tel: + 41 22 919 02 11
Fax: + 41 22 919 03 00
info@iec.ch
www.iec.ch